



## Product Parts and Dimensions

**25-YEAR**  
LIMITED PRODUCT WARRANTY

**LONG-TERM**  
DURABILITY

**HIGHEST**  
QUALITY MATERIALS

By custom designing and manufacturing components in-house, Solar Foundations' structures fit and function together seamlessly, install in far less time and with greater strength. The highest quality materials such as high-grade steel fully galvanized in accordance with ASTM standards and high-strength aluminum alloys for our panel support rails are utilized for long-term durability.



Solar Foundations USA®, Inc.  
1142 River Road, New Castle, DE 19720  
Phone (855) 738-7200  
Fax (866) 644-5665  
[www.solarfoundationsusa.com](http://www.solarfoundationsusa.com)

© Solar Foundations USA®, All Rights Reserved

Product\_Datasheets\_Rev0\_20190410

*INNOVATIVE. ADAPTABLE. GROUNDED.*

**Table of Contents**

Solar Continuous Flight Helical Pile	.....	1
Solar Pile Extension	.....	2
Horizontal Beams - Hollow Structural Sections (HSS)	.....	3
Column Cap	.....	4
Wind Brace	.....	6
Ground Mount Rail	.....	8
Rail Mounting Hardware	.....	9
End Clamp	.....	10
Mid Clamp (Standard Non-Bonding)	.....	11
Mid Clamp (WEEB Bonding)	.....	12
Black Panel Hardware - Black End Clamp	.....	14
Black Panel Hardware - Black Mid Clamp (Standard Non-Bonding)	.....	15
Black Panel Hardware - Black Mid Clamp (WEEB Bonding)	.....	16
25-Year Limited Product Warranty	.....	18



Part Number	Description	Material	Finish	Patent
CF70	2.50" Sch 40 HDG Continuous Flight Helical Pile w/ NPT Threads, 70" Long	ASTM A500 Grade C	Hot-Dipped Galvanized to ASTM A123/A123M	Patent Pending
CF84	2.50" Sch 40 HDG Continuous Flight Helical Pile w/ NPT Threads, 84" Long			
CF126	2.50" Sch 40 HDG Continuous Flight Helical Pile, 126" Long			

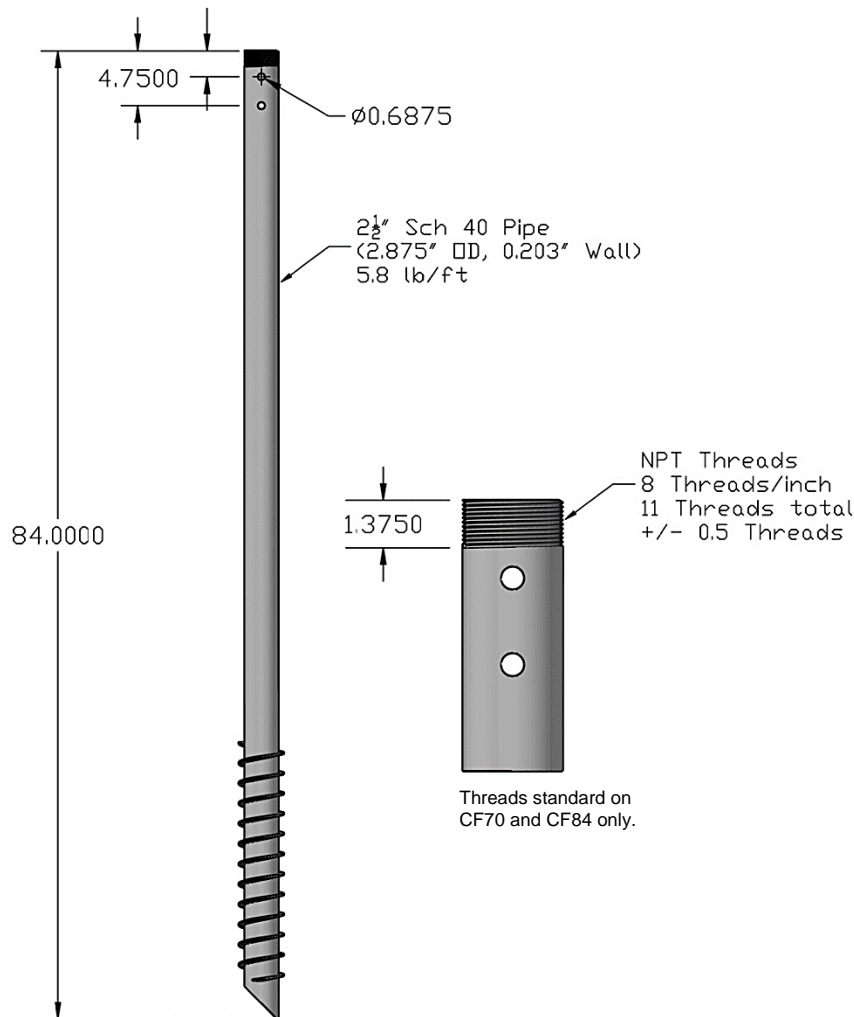

2 1/2" Schedule 40 Round Pile Section Properties	
Axis X-X Value	Value
I (Moment of Inertia)	1.450 in <sup>4</sup>
S (Section Modulus)	1.010 in <sup>3</sup>
r (Radius of Gyration)	0.952 in
Z (Plastic Modulus)	1.370 in <sup>3</sup>
Axis Y-Y Value	Value
I (Moment of Inertia)	1.450 in <sup>4</sup>
S (Section Modulus)	1.010 in <sup>3</sup>
r (Radius of Gyration)	0.952 in
Z (Plastic Modulus)	1.370 in <sup>3</sup>
Outside Diameter	2.875 in
Wall Thickness	0.203 in
Area	1.590 in <sup>2</sup>
Weight	5.813 lb/lf
Installation Torque Factor	8-9
Axial Compressive Load Limit	47,000 lbs
Axial Tensile Load Limit	47,000 lbs
Torsional Installation Limit	5,000 ft-lb
Max Developed Axial Capacity	40,000 lbs
Max Lateral Load Capacity	2,300 lbs

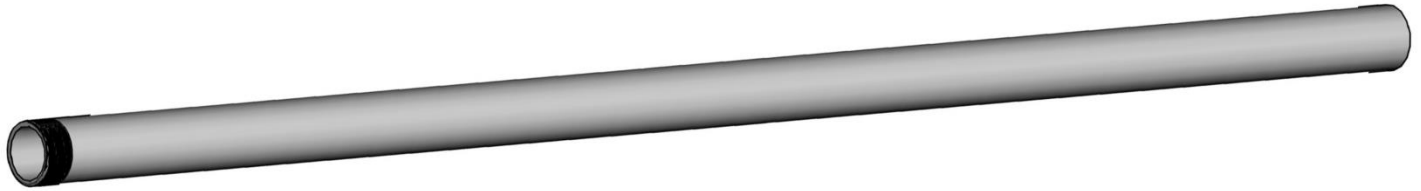

Part Number	Description	Material	Finish
X84	2-1/2" Sch 40 HDG Pile Extension, 84" Long Threaded One End	ASTM A53 Grade A	Hot Dipped Galvanized to ASTM A123 / A123M
X126	2-1/2" Sch 40 HDG Pile Extension, 126" Long Threaded One End		

<b>2½" Schedule 40 Extension Section Properties</b>	
<b>Axis X-X Value</b>	<b>Value</b>
I (Moment of Inertia)	1.450 in <sup>4</sup>
S (Section Modulus)	1.010 in <sup>3</sup>
r (Radius of Gyration)	0.952 in
Z (Plastic Modulus)	1.370 in <sup>3</sup>
<b>Axis Y-Y Value</b>	<b>Value</b>
I (Moment of Inertia)	1.450 in <sup>4</sup>
S (Section Modulus)	1.010 in <sup>3</sup>
r (Radius of Gyration)	0.952 in
Z (Plastic Modulus)	1.370 in <sup>3</sup>
Outside Diameter	2.875 in
Wall Thickness	0.203 in
Area	1.590 in <sup>2</sup>
Weight	5.813 lb/lf

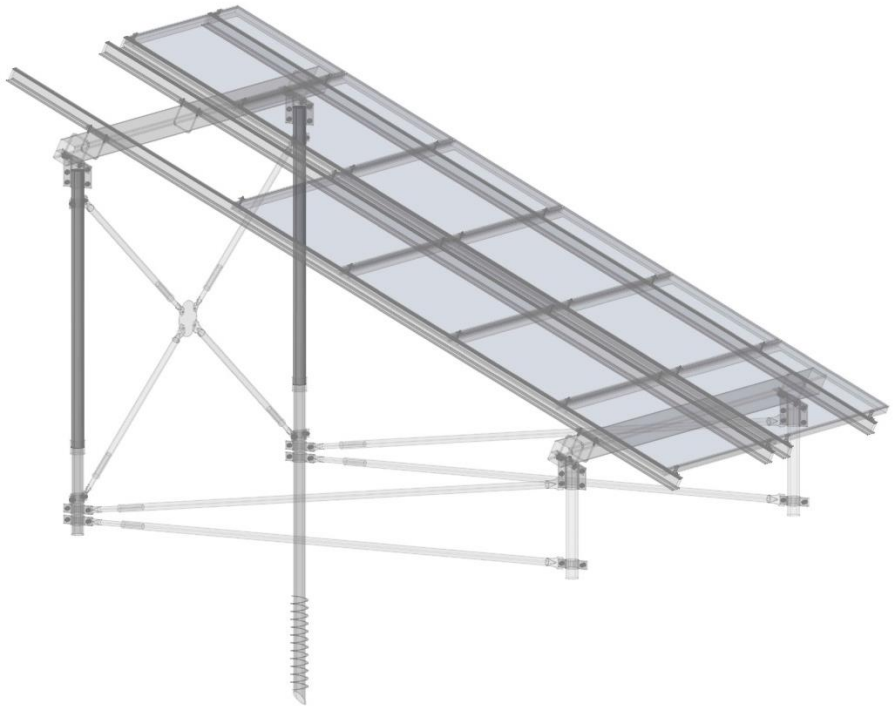

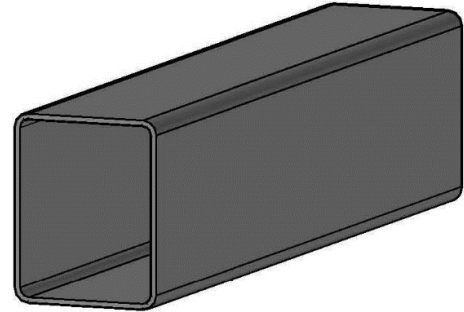
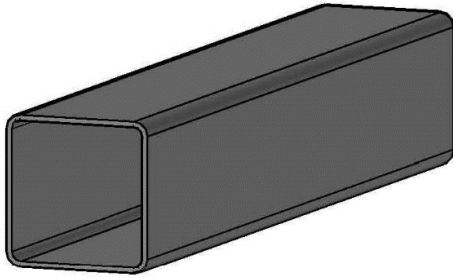

<b>4"x4" HDG Hollow Structural</b>	
<b>Axis X-X</b>	<b>Value</b>
I (Moment of Inertia)	4.40 in <sup>4</sup>
S (Section Modulus)	2.20 in <sup>3</sup>
r (Radius of Gyration)	1.580 in
Z (Plastic Modulus)	2.560 in <sup>3</sup>
<b>Axis Y-Y</b>	
I (Moment of Inertia)	4.40 in <sup>4</sup>
S (Section Modulus)	2.20 in <sup>3</sup>
r (Radius of Gyration)	1.580 in
Z (Plastic Modulus)	2.560 in <sup>3</sup>
Wall Thickness	0.116 in
Area	1.770 in <sup>2</sup>
Weight	6.448 plf

<b>5"x4" HDG Hollow Structural</b>	
<b>Axis X-X</b>	<b>Value</b>
I (Moment of Inertia)	7.42 in <sup>4</sup>
S (Section Modulus)	2.97 in <sup>3</sup>
r (Radius of Gyration)	1.93 in
Z (Plastic Modulus)	3.50 in <sup>3</sup>
<b>Axis Y-Y</b>	
I (Moment of Inertia)	5.27 in <sup>4</sup>
S (Section Modulus)	2.64 in <sup>3</sup>
r (Radius of Gyration)	1.62 in
Z (Plastic Modulus)	3.01 in <sup>3</sup>
Wall Thickness	0.116 in
Area	2.00 in <sup>2</sup>
Weight	7.298 plf

<b>Part Number</b>	<b>Description</b>	<b>Material</b>	<b>Yield Strength</b>	<b>Finish</b>
TS5418.75	5"x4" HDG Rectangular Hollow Structural Section (HSS), 1/8" wall, 18.75' Long	ASTM A500 high yield	60 ksi yield minimum	Hot Dipped Galvanized to ASTM A123 / A123M
TS5420	5"x4" HDG Rectangular Hollow Structural Section (HSS), 1/8" wall, 20' Long			
TS4418.75	4"x4" HDG Rectangular Hollow Structural Section (HSS), 1/8" wall, 18.75' Long			
TS4420	4"x4" HDG Rectangular Hollow Structural Section (HSS), 1/8" wall, 20' Long			

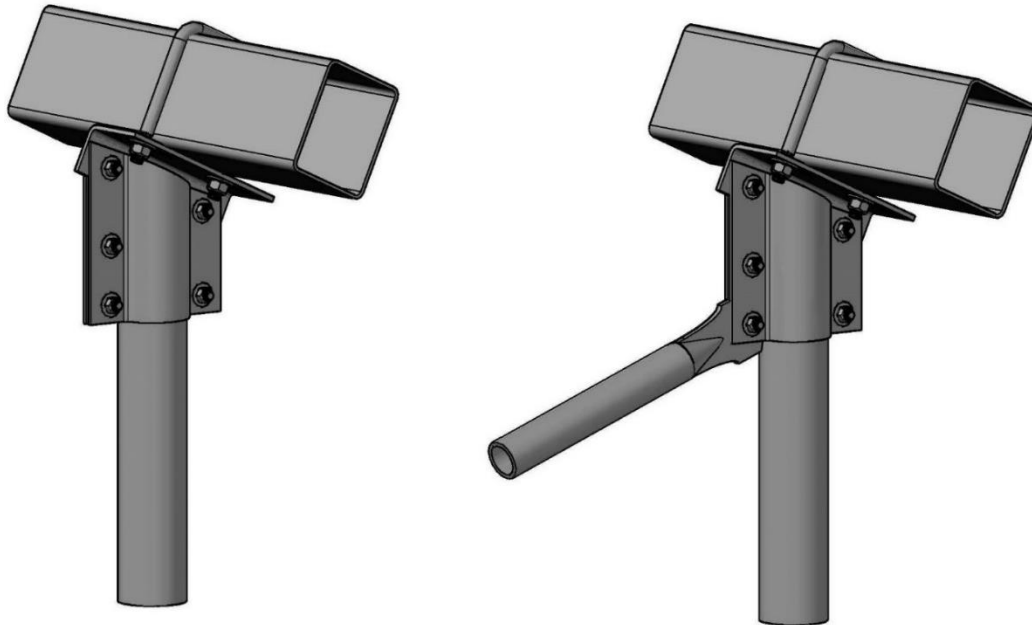

Item Number	Part Number	Description	Material	Finish	Patent	Quantity Required			
1	CHW	West Cap Half	ASTM A1011 CS Type B	Hot-dipped galvanized in accordance with ASTM A153/A153M	Patent No. 8,939,143 8,939,144 9,571,029 9,660,568	1			
2	CHE	East Cap Half							
3	LPL	L-Plate for 00-20 Degree Array Tilt	ASTM A36						
4	LPS	L-Plate for 18-35 Degree Array Tilt							
5	LPH	L-Plate for 32-47 Degree Array Tilt							
6	B6G1.25	3/8"-16 HDG Hex Head Bolt, 1.25" Long	SAE Grade 5				SAE Grade 2	16 (North) 13 (South)	5
7	NH6G	3/8"-16 HDG Heavy Hex Nut							
8	W6G	3/8" HDG USS Series Flat Washers							
9	BU54	1/2" Square Bend U-Bolt (5x4 HSS)	Grade 2						1
10	BU44	1/2" Square Bend U-Bolt (4x4 HSS)							

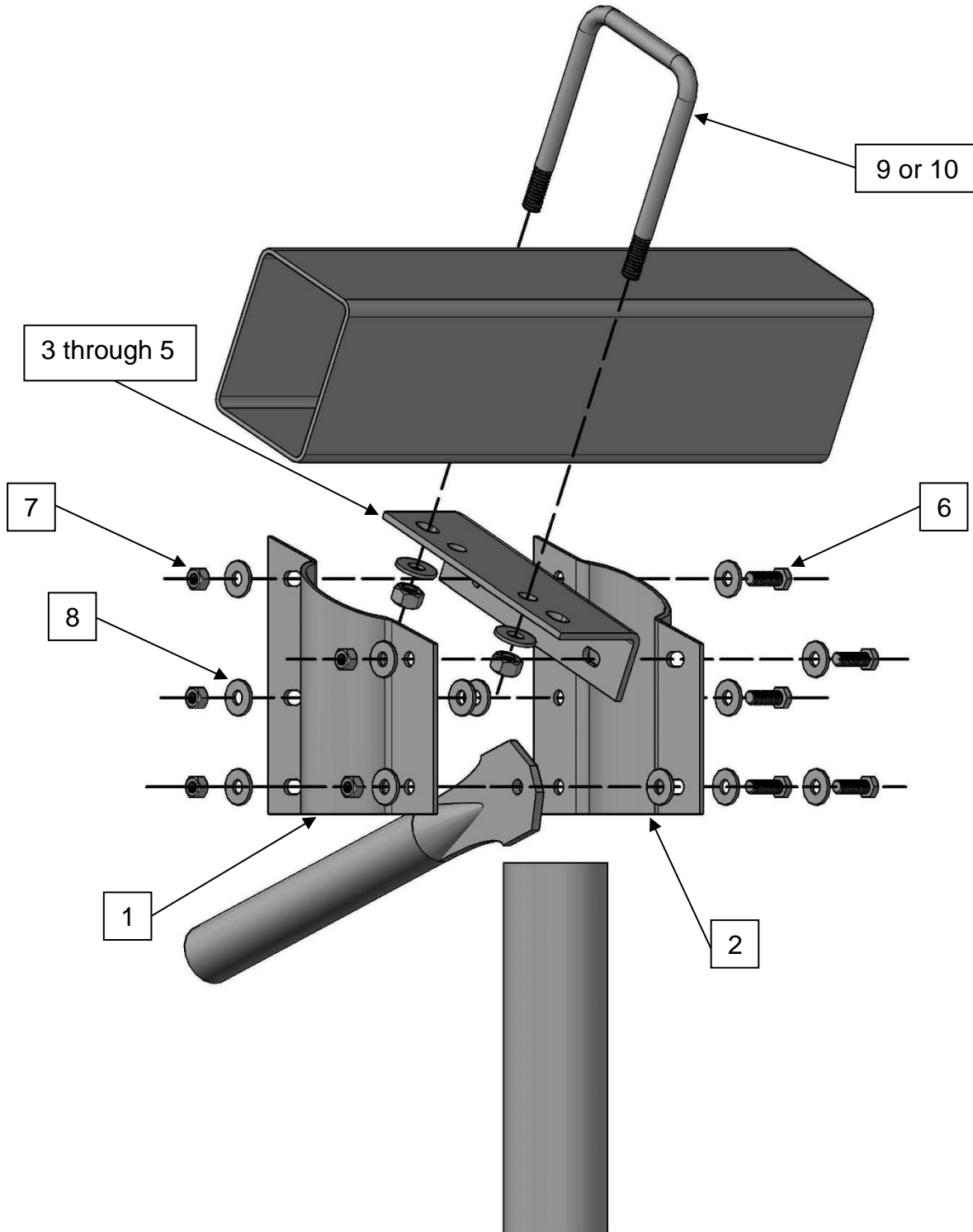

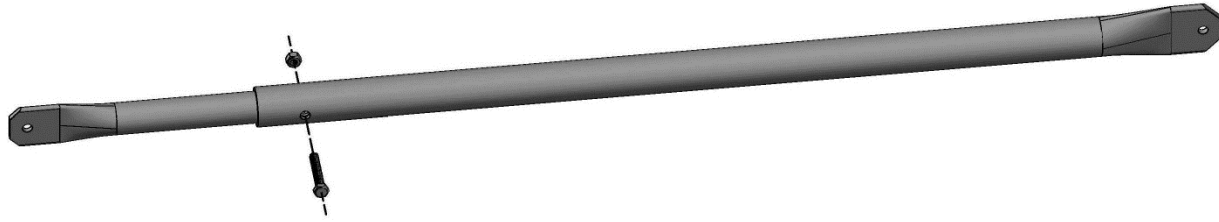

Item Number	Part Number	Quantity Required	Description	Material	Finish	Patent
1	WB84	1	1-1/4" Sch 40 HDG Wind Brace, 84" Long	ASTM A53 Grade A	Hot-dipped galvanized in accordance with ASTM A123/A123M	Patent No. 9,447,990
2	WB116		1-1/4" Sch 40 HDG Wind Brace, 116" Long			
3	WBI-25		1-1/4" Sch 40 HDG Wind Brace Insert, 25" Long			
4	W6G	4	3/8" HDG USS Series Flat Washers	SAE Grade 2	Hot-dipped galvanized in accordance with ASTM A153/A153M	
5	NH6G	3	3/8-16 HDG Heavy Hex Nut	SAE Grade 2		
6	B6G1.25	2	3/8-16 HDG Hex Head Bolt, 1.25" Long	SAE Grade 5		
7	B6G2.25	1	3/8-16 HDG Hex Head Bolt, 2.25" Long	SAE Grade 2		
8	WBC	2	Wind Brace Column Connector	ASTM A1011 CS		

- 1-1/4" Sch 40 HDG Wind Brace, 84" Long
- 1-1/4" Sch 40 HDG Wind Brace, 116" Long
- 1" Sch 40 HDG Wind Brace Insert, 25" Long

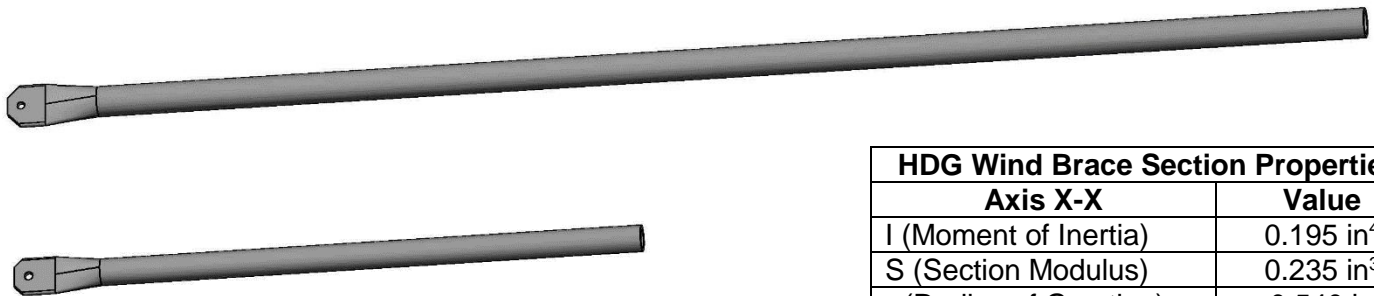

HDG Wind Brace Section Properties	
Axis X-X	Value
I (Moment of Inertia)	0.195 in <sup>4</sup>
S (Section Modulus)	0.235 in <sup>3</sup>
r (Radius of Gyration)	0.540 in
Axis Y-Y	
Value	
I (Moment of Inertia)	0.195 in <sup>4</sup>
S (Section Modulus)	0.235 in <sup>3</sup>
r (Radius of Gyration)	0.540 in
Outside Diameter	1.660 in
Wall Thickness	0.140 in
Area	0.669 in <sup>2</sup>
Weight	2.27 plf



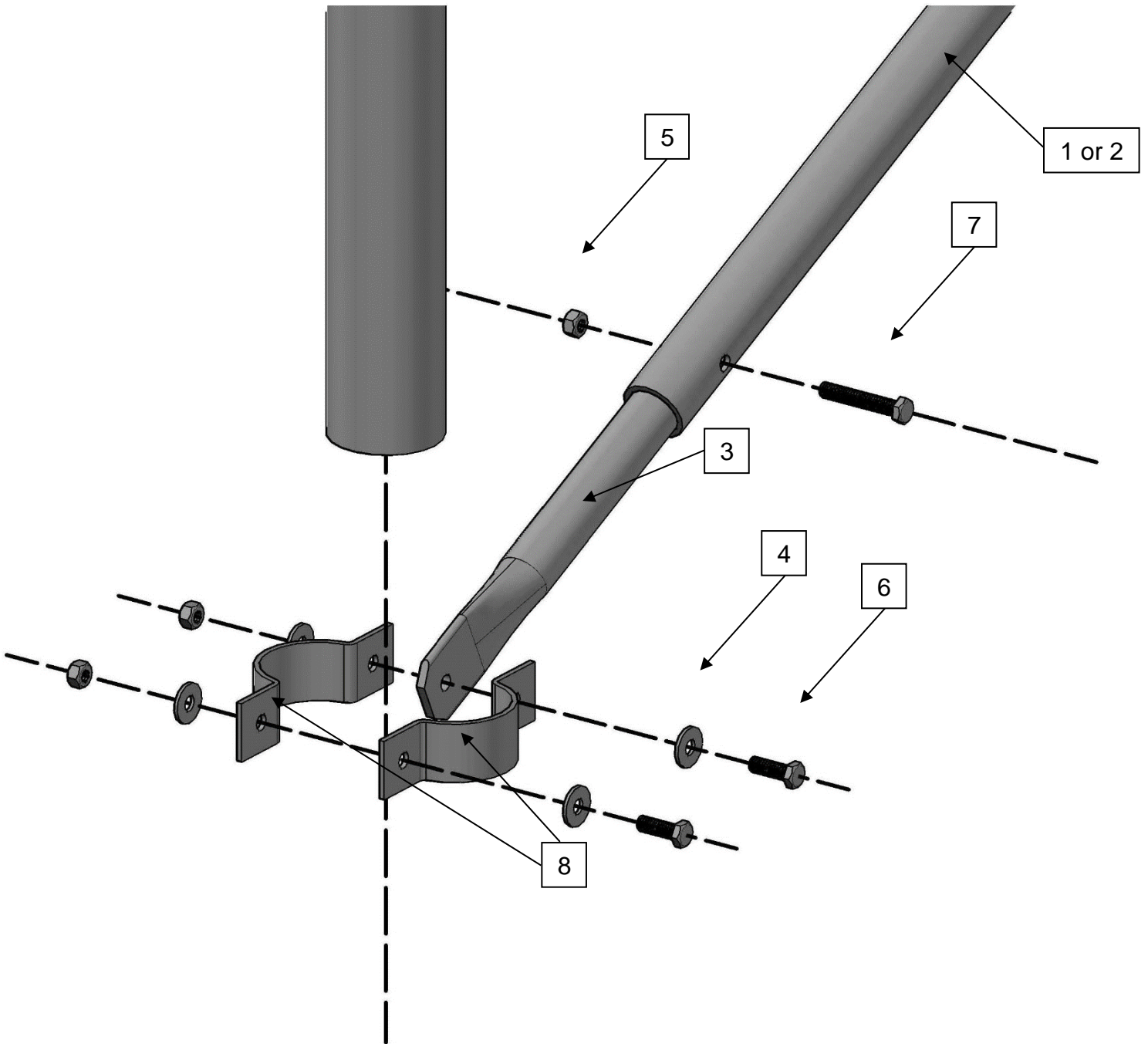

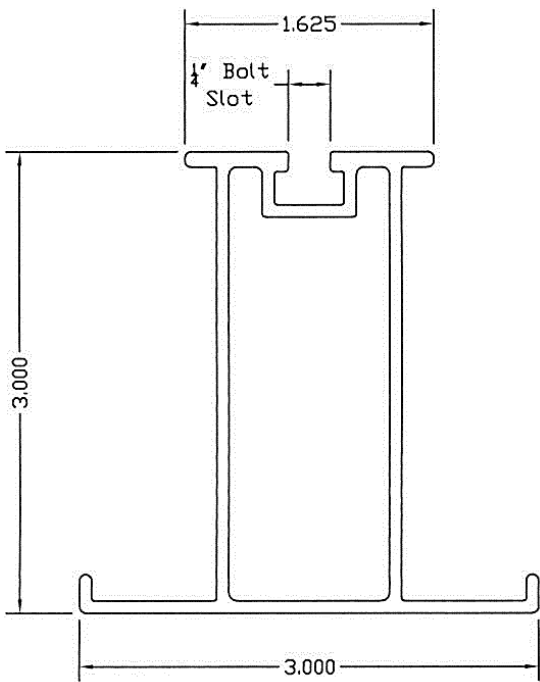
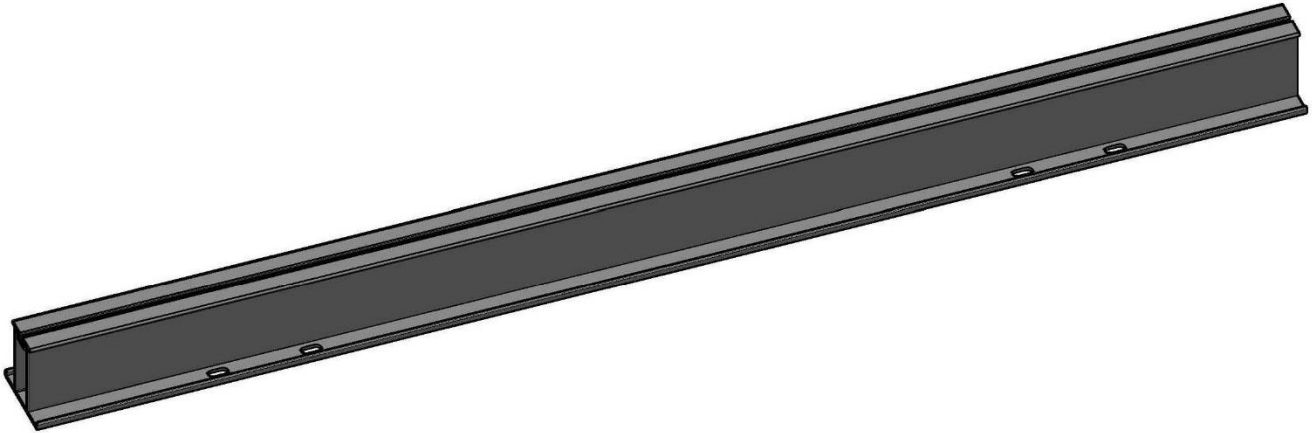

Rail Section Properties	
Axis X-X	Value
I (Moment of Inertia)	1.27 in <sup>4</sup>
S (Section Modulus)	0.80 in <sup>3</sup>
R (Radius of Gyration)	1.152 in
Z (Plastic Modulus)	0.802 in <sup>3</sup>
Axis Y-Y	Value
I (Moment of Inertia)	0.418 in <sup>4</sup>
S (Section Modulus)	0.278 in <sup>3</sup>
r (Radius of Gyration)	0.664 in
Z (Plastic Modulus)	0.278 in <sup>3</sup>
Area	0.947 in <sup>2</sup>
Weight	1.085 plf

Item Number	Part Number	Description/Length	Panel Width	Material	Weight	Patent
1	R162	SFUSA (4) Ground Mount Rail, 162"	38.58" – 39.41"	Aluminum 6005A – T61	15.3 lbs.	Patent No. 8,776,454 Patent No. 9,249,994 Patent No. 9,660,569
2	R171	SFUSA (4) Ground Mount Rail, 171"	39.42" – 41.20"		16.1 lbs.	
3	R202	SFUSA (5) Ground Mount Rail, 202"	38.58" – 39.41"		19.0 lbs.	
4	R212	SFUSA (5) Ground Mount Rail, 212"	39.42" – 41.20"		20.0 lbs.	
5	R242	SFUSA (6) Ground Mount Rail, 242"	38.58" – 39.41"		22.8 lbs.	
6	R254	SFUSA (6) Ground Mount Rail, 254"	39.42" – 41.20"		23.9 lbs.	

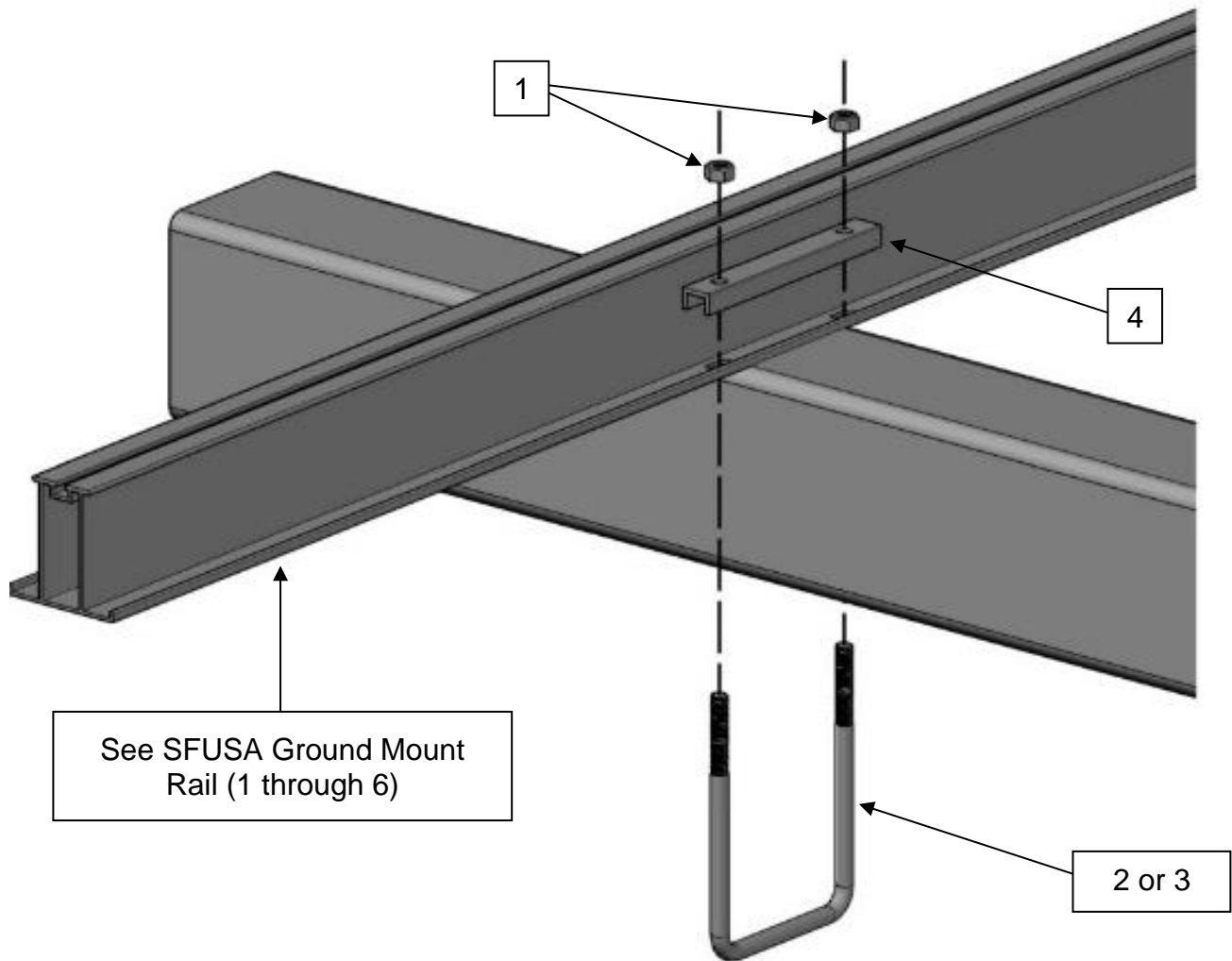

Item Number	Part Number	Quantity Required	Description	Material	Finish
1	N6G	2	3/8-16 HDG Finished Hex Nut	SAE Grade 2	Hot-dipped galvanized in accordance with ASTM A153/A153M
2	RU54	1	3/8" Rail Mounting U-Bolt (5x4 HSS)	Grade 2	
3	RU44		3/8" Rail Mounting U-Bolt (4x4 HSS)		
4	SAD4	1	SF Rail Clamping Saddle	ASTM 1006	

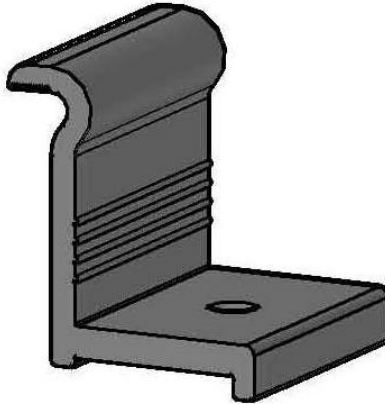

Part Number	Height mm	Panel Thickness mm	Material	Finish
EC31	31	30 - 32	Aluminum 6063 – T6	Mill
EC33	33	>32 - 34		
EC35	35	>34 - 36		
EC38	38	37 - 39		
EC40	40	>39 – 41		
EC42	42	>41 - 43		
EC46	46	45 - 47		
EC48	48	>47 - 49		
EC50	50	>49 - 51		

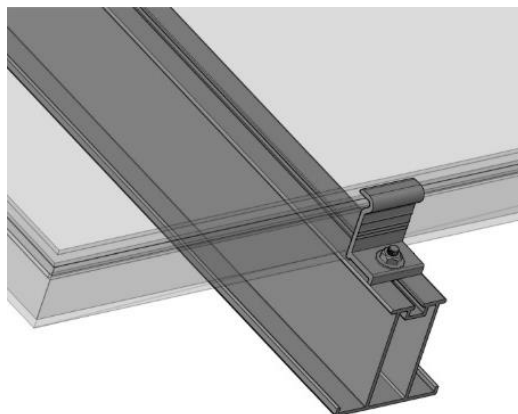
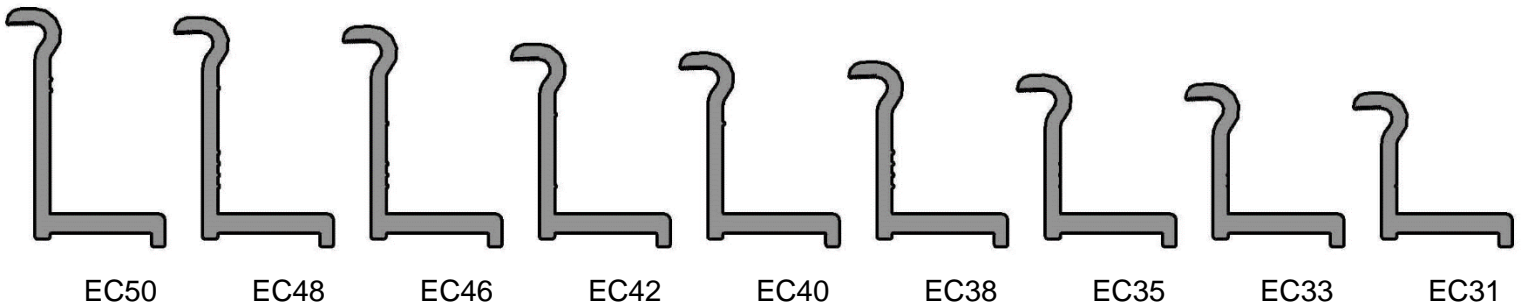

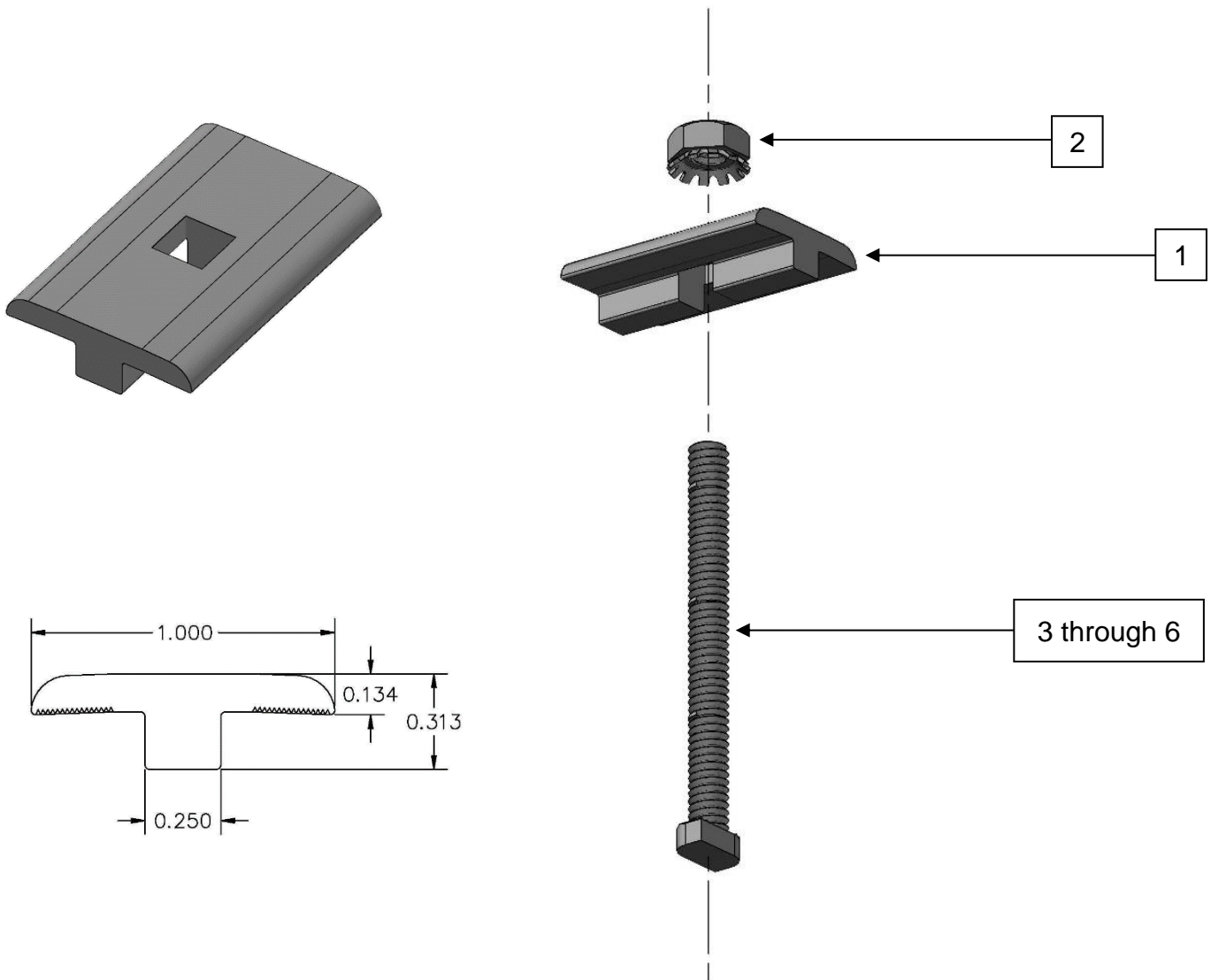

Item Number	Part Number	Description	Material	Finish
1	MC	Standard Module Mid Clamp	Aluminum 6063 – T6	Mill
2	KLOCK	K-Lock Nut (1/4-20)	300 Series Stainless Steel	
3	T2.00	SFUSA T-Head Bolt, 2.00" Long (1/4-20)		
4	T2.25	SFUSA T-Head Bolt, 2.25" Long (1/4-20)		
5	T2.50	SFUSA T-Head Bolt, 2.50" Long (1/4-20)		
6	T2.75	SFUSA T-Head Bolt, 2.75" Long (1/4-20)		

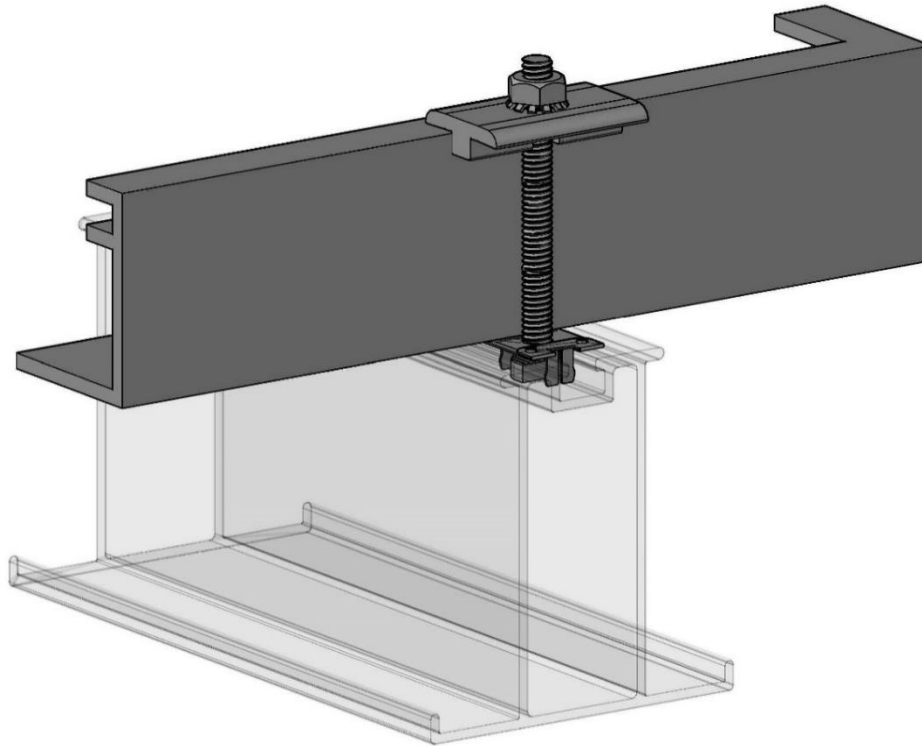

Item Number	Part Number	Description	Material	Finish
1	MC	Standard Module Mid Clamp	Aluminum 6063 – T6	Mill
2	KLOCK	K-Lock (1/4-20)	300 Series Stainless Steel	
3	T2.00	SFUSA T-Head Bolt, 2.00" Long (1/4-20)		
4	T2.25	SFUSA T-Head Bolt, 2.25" Long (1/4-20)		
5	T2.50	SFUSA T-Head Bolt, 2.50" Long (1/4-20)		
6	T2.75	SFUSA T-Head Bolt, 2.75" Long (1/4-20)		
7	DMC	WEEB DMC Bonding Washer		

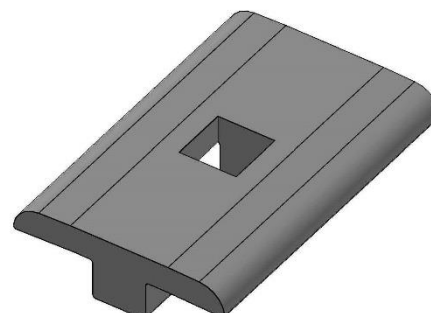
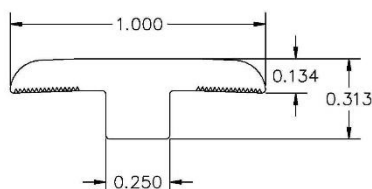

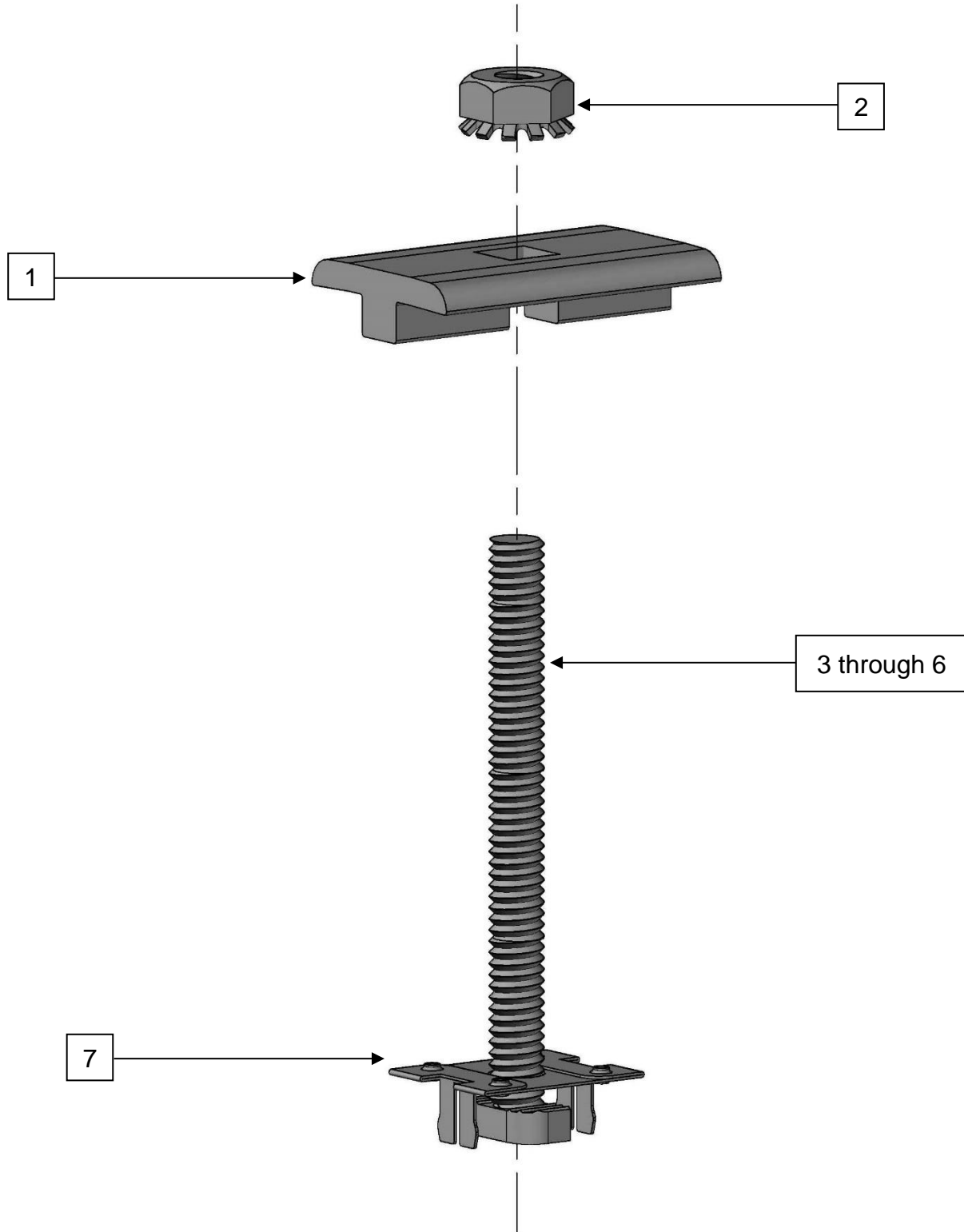

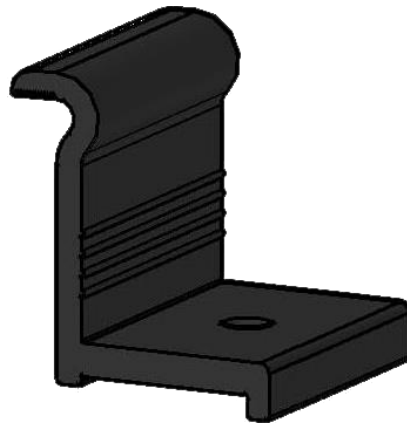

Part Number	Height mm	Panel Thickness mm	Material	Finish
BEC31	31	30 - 32	Aluminum 6063 – T6	Black Anodized
BEC33	33	>32 - 34		
BEC35	35	>34 - 36		
BEC38	38	37 - 39		
BEC40	40	>39 – 41		
BEC46	46	45 - 47		

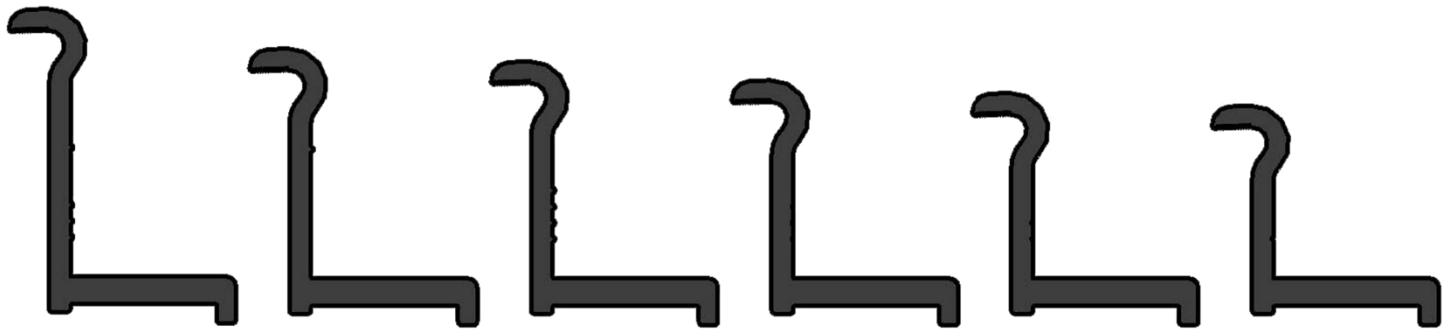

BEC46      BEC40      BEC38      BEC35      BEC33      BEC31



BEC46      BEC40      BEC38      BEC35      BEC33      BEC31



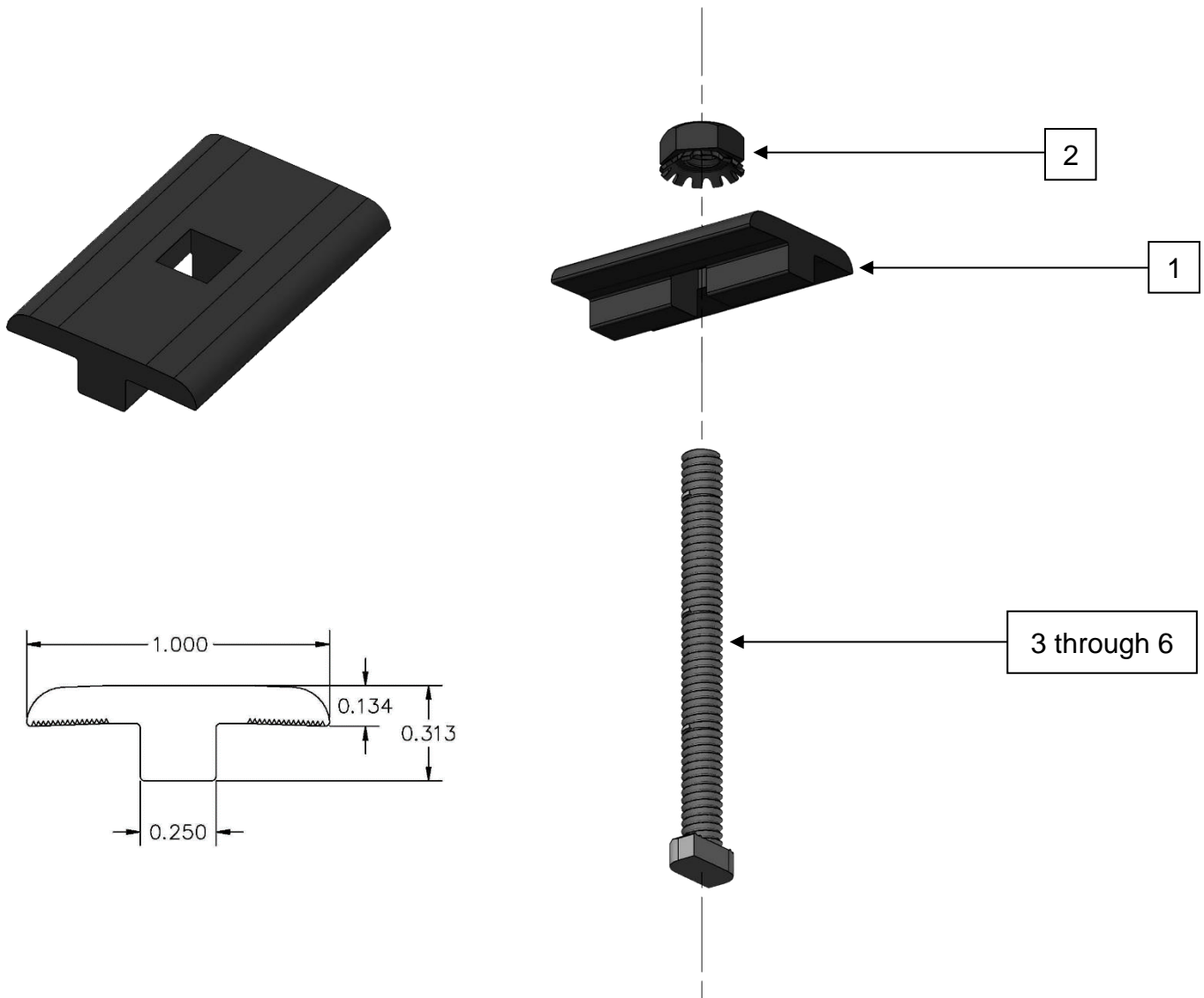

Item Number	Part Number	Description	Material	Finish
1	BMC	Black Standard Module Mid Clamp	Aluminum 6063 – T6	Black Anodized
2	BKLOCK	Black K-Lock Nut (1/4-20)	300 Series Stainless Steel	Black Oxide
3	T2.00	SFUSA T-Head Bolt, 2.00" Long (1/4-20)	300 Series Stainless Steel	
4	T2.25	SFUSA T-Head Bolt, 2.25" Long (1/4-20)		
5	T2.50	SFUSA T-Head Bolt, 2.50" Long (1/4-20)		
6	T2.75	SFUSA T-Head Bolt, 2.75" Long (1/4-20)		

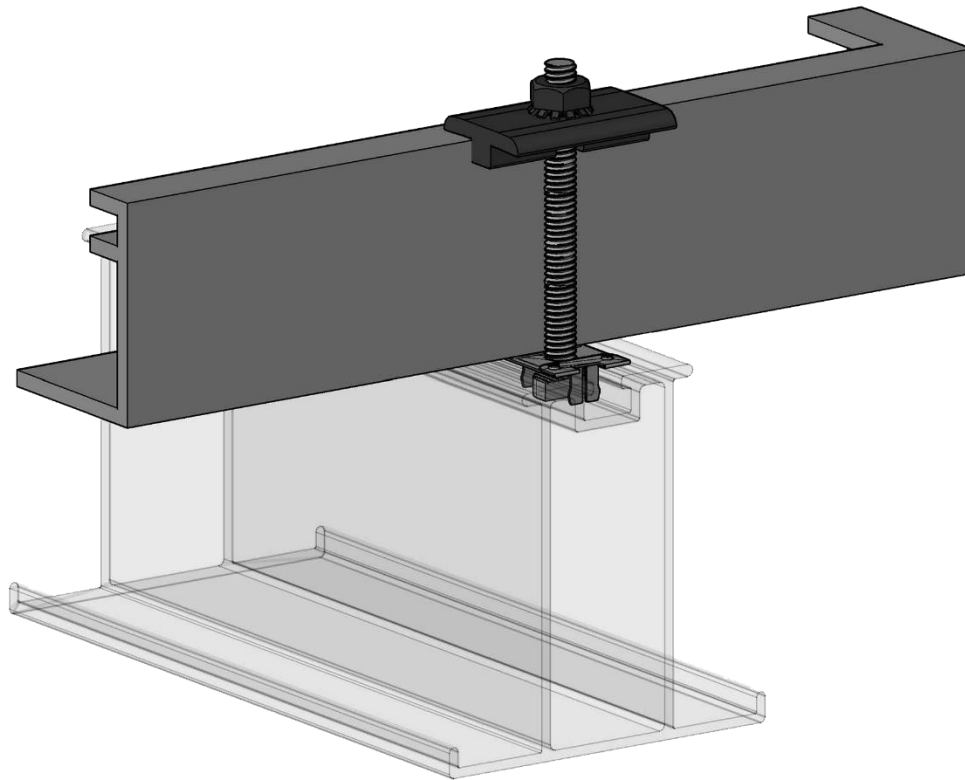

Item Number	Part Number	Description	Material	Finish
1	BMC	Black Standard Module Mid Clamp	Aluminum 6063 – T6	Black Anodized
2	BKLOCK	Black K-Lock Nut (1/4-20)	300 Series Stainless Steel	Black Oxide
3	T2.00	SFUSA T-Head Bolt, 2.00" Long (1/4-20)	300 Series Stainless Steel	
4	T2.25	SFUSA T-Head Bolt, 2.25" Long (1/4-20)		
5	T2.50	SFUSA T-Head Bolt, 2.50" Long (1/4-20)		
6	T2.75	SFUSA T-Head Bolt, 2.75" Long (1/4-20)		
7	DMC	WEEB DMC Bonding Washer		

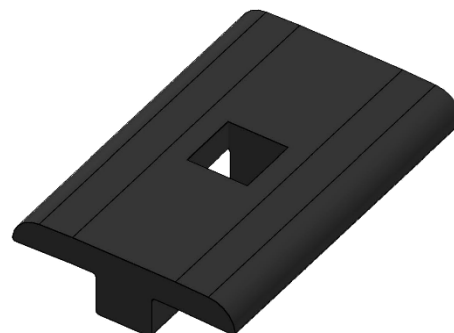
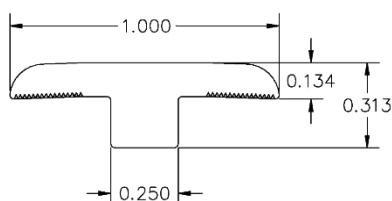

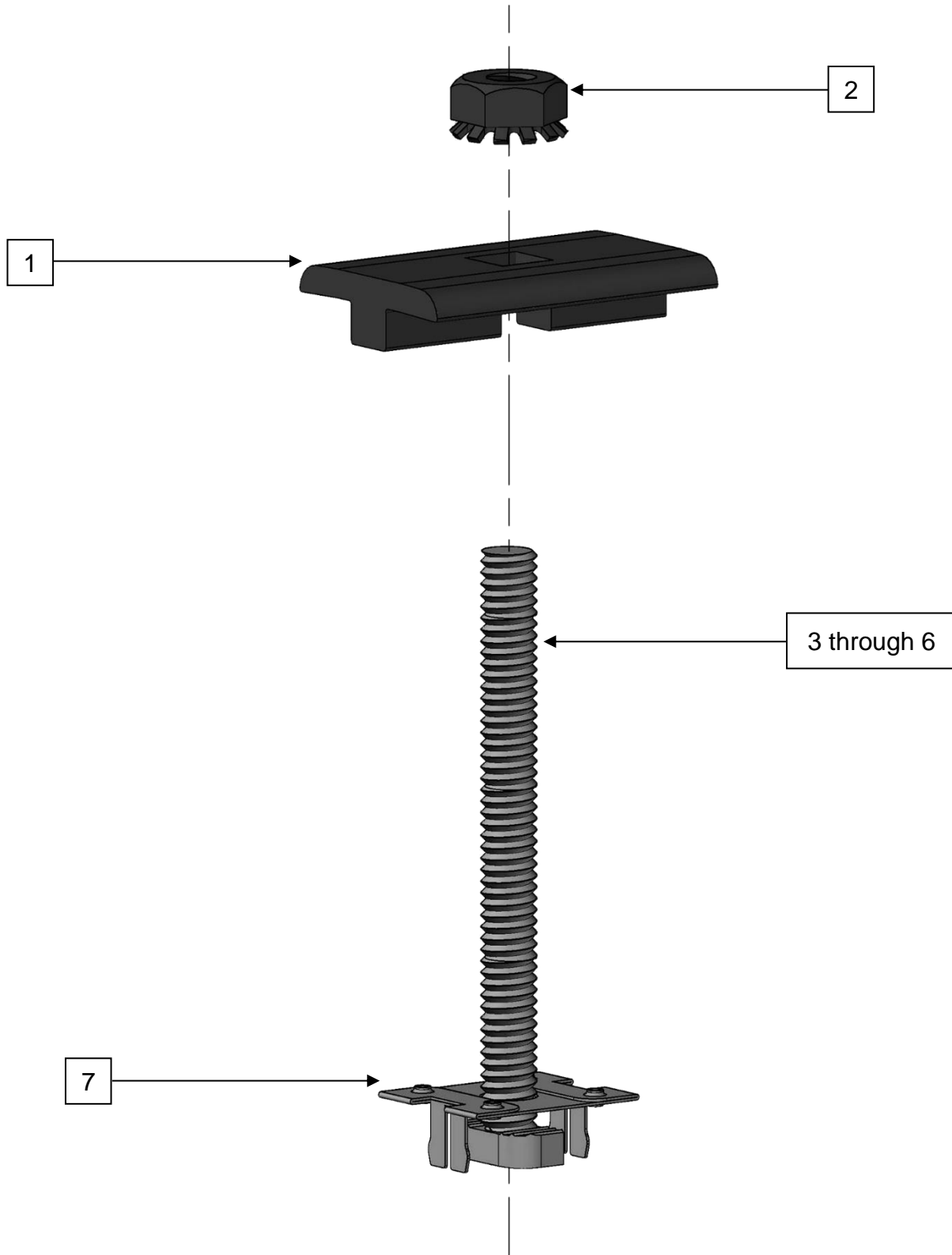

## **25-Year Limited Product Warranty**

Solar Foundations USA<sup>®</sup>, Inc., warrants to the original purchaser of the product (“Purchaser”), that its products (“Product”) shall be free from defects in materials and workmanship under normal and proper usage for a period of twenty-five (25) years from the date of shipment by Solar Foundations USA<sup>®</sup>, Inc. This Limited Warranty does not cover damage during shipment, nor damage prior to or during installation. If within the Limited Warranty period, the Product shall be reasonably proven to be defective, then Solar Foundations USA<sup>®</sup>, Inc., at its sole discretion, shall replace or repair the defective Product or any part thereof. Solar Foundations USA<sup>®</sup>, Inc.’s total liability hereunder for the Product repair or replacement shall not exceed the original purchase price of the Product. Such repair or replacement shall fulfill all Solar Foundations USA<sup>®</sup>, Inc.’s liability with respect to this Limited Warranty. Under no circumstances shall Solar Foundations USA<sup>®</sup>, Inc. be liable for special, indirect or consequential damages arising out of or related to the use of the Product by the Purchaser. Solar Foundations USA<sup>®</sup>, Inc.’s Limited Warranty only applies to its Product. Typical Product installations may include consumer products made by other manufacturers. The Purchaser shall look solely to the manufacturer of any such consumer products with respect to any warranties or claims in connection therewith and hereby releases Solar Foundations USA<sup>®</sup>, Inc. from any liabilities, obligations, claims and/or damages with respect to the consumer products which may be installed in conjunction with the Product.

This Limited Warranty shall be void if installation of the Product is not performed in accordance with Solar Foundations USA<sup>®</sup>, Inc. written installation manual for the Product, or if the Product has been modified, repaired or reworked in a manner not previously authorized in writing by Solar Foundations USA<sup>®</sup>, Inc., or if the Product is installed in an environment for which it was not designed or if the Purchaser fails to provide necessary preventive maintenance such as re-application of cold galvanizing compound as needed.

The remedies provided in the above limited warranty are the sole and exclusive remedies available to the Purchaser. No other express warranties are made. All implied warranties, including but not limited to any implied warranty of merchantability or fitness for a particular purpose or use, are limited in duration as set forth above. In no event shall Solar Foundations USA<sup>®</sup>, Inc. be liable for any consequential, contingent, incidental, economic or property damage or personal injuries or death arising out of the use of the Product by the Purchaser. Some states do not allow the exclusion of incidental or consequential damages or damages for personal injury or death.

The agents, employees and independent contractors of Solar Foundations USA<sup>®</sup>, Inc. are not authorized to modify this Limited Warranty or give additional warranties binding on Solar Foundations USA<sup>®</sup>, Inc.